

D1/D2 REPOWERING KIT

Easier installation of your new D1 or D2 diesel engine

Give your boat a new life by replacing your old engine with a new Volvo Penta D1 or D2 diesel engine. The D1/D2 Repowering Kit will make it easier to install the new engine.

The D1/D2 Repowering Kit consists of brackets that match the new engine with your existing engine bed perfectly. This secures low vibrations and minimal impact to the existing engine bed.

With a new Volvo Penta engine installed, you will experience the advantages of improved maneuverability, quieter operation, increased performance and charging capacity. You'll also boost the value of your boat.

The D1/D2 Repowering Kit is available for engines in both shaft and Saildrive installations. Please see the next page for a complete list of possible engine replacements.

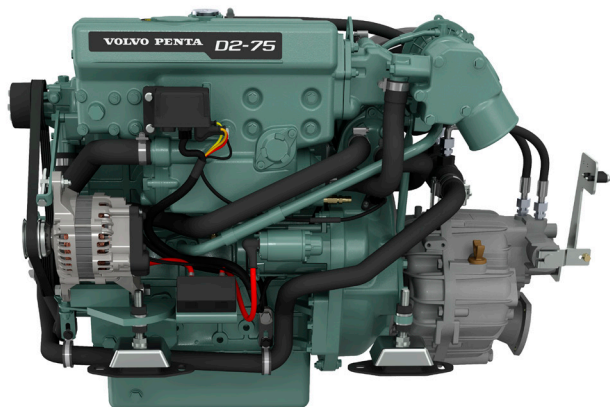
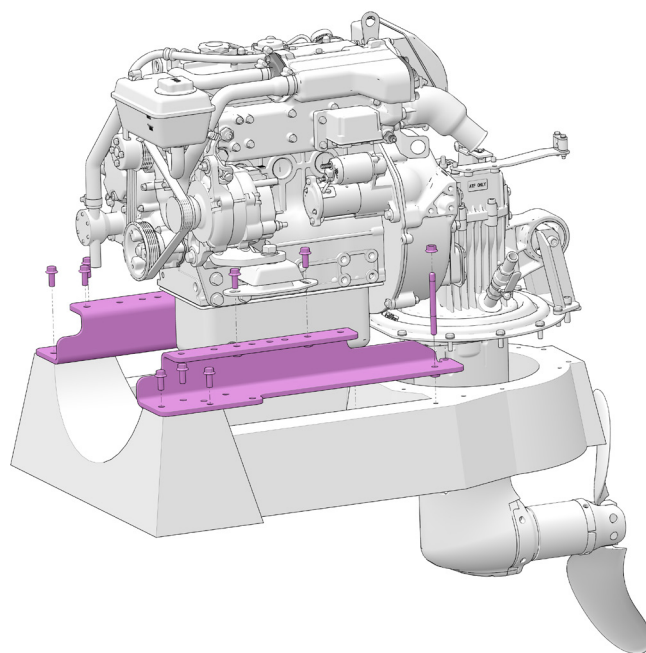

The compact and reliable D1 and D2 diesel engines are available from 12 to 75 hp.

Made to match with existing engine bed

The D1/D2 Repowering Kit contains a unique set of components required for the specific engine replacement. The brackets are designed to perfectly match the new engine to your existing engine bed, minimizing time consuming fiberglass work. The installation will ensure low vibrations and a quiet boat operation.

Depending on your engine series, the D1/D2 Repowering Kit consists of:

- Brackets
- Screws and nuts
- Installation instruction

D1/D2 REPOWERING KIT

Easier installation of your new D1 or D2 diesel engine

Features:

- Simplifies repowering
- Made to match with existing engine bed
- Minimized fiberglass work
- Minimal vibrations for high onboard comfort
- Developed and tested by Volvo Penta

Below you'll find possible engine replacements available with the D1/D2 Repowering Kit. Always advise your Volvo Penta dealer about which replacement you and your boat will most benefit from. For further engine information, please see the engine Product Leaflet available on www.volvopenta.com.

Engines with shaft

Volvo Penta to Volvo Penta

	D1-13	D1-20	D1-30	D2-50	D2-60	D2-75
MD1/2/3	●	●	●			
MD5/6/7/11	●	●	●			
MD17	●	●	●	●	●	●
MD21				●	●	●
2001/2/3/3T	●	●	●			
MD2010	●	●	●			
MD2020/30	●	●	●			
MD2040				●	●	●
MD22				●	●	●
TMD22				●	●	●

Note: For above installations, the existing reverse gear must be replaced.

Yanmar to Volvo Penta

	D1-13	D1-20	D1-30	D2-50	D2-60	D2-75
1GM/10	●	●	●			
2GM	●	●	●			
3GM/D	●	●	●			
2QM15	●	●	●			
2GM20	●	●	●			
3YM20/30	●	●	●			
2YM15	●	●	●			
3HM	●	●	●			
YSE8	●	●	●			
4JH45-KM35P				●	●	●
4JH45-ZF30M				●	●	●
3QM30			●			
3QM30H/Y			●			
3QM30F			●			

Note: For above installations, the existing reverse gear must be replaced.

Engines with saildrive

Volvo Penta to Volvo Penta

	D1-13	D1-20	D1-30	D2-50	D2-60	D2-75
MD5	●	●	●			
MD6/7/11	●	●	●			
MD17	●	●	●	●	●	●
MD21				●	●	●
2001/2	●	●	●			
2003/3T	●	●	●			
MD2010	●	●	●			
MD2020/30	●	●	●			
MD2040				●	●	●
MD22				●	●	●
TMD22				●	●	●

Note: For above installations, the existing Saildrive must be replaced, except for the 120S Saildrive where a separate kit for D1-13 to D2-40 is available.

Yanmar to Volvo Penta

	D1-13	D1-20	D1-30	D2-50	D2-60	D2-75
All engines with saildrive	●	●	●	●	●	●

Note: For above installations, the existing saildrive must be replaced

Universal repowering kits for engines with shaft

If you don't find your engine in the tables, Volvo Penta offers universal repowering kits which make it easier to replace any engine brand with a Volvo Penta D1 or D2 engine.

Please contact your local Volvo Penta dealer for further information. Please note that products illustrated may differ from production models. Not all models and accessories are available in all markets, and standard equipment may vary between different markets. Every effort has been made to ensure that facts and figures are correct at the time of publication. However, Volvo Penta reserves the right to make changes without prior notice at any time.

VOLVO PENTA

AB Volvo Penta

SE-405 08 Göteborg, Sweden
www.volvopenta.com