

VOLVO PENTA RUBBER STUFFING BOX



The rubber stuffing box is a well proven product for sealing and lubrication. It can be used on any marine vessel that comes with shaft installation.

Long time sealing

The rubber stuffing box provides versatility and long time sealing with very limited maintenance.

Volvo Penta design

The seal is a Volvo Penta design with all the requirements for safety, functionality and ease of assembly that have become a trademark for Volvo Penta products. The functionality is as secure and faultfree as the design is simple.

Maintenance

The rubber stuffing box offers a low maintenance solution and yet offers a long life span when handled properly. Apply grease every 200 running hours or once a year for a many years faultless function.

Easy to install

The seal is very easy to install due to it's compact and simple design. It will provide a long lasting and low cost solution that already is so appealing to many boaters in the world. Some installations may require extra water supply to offer proper function.

Benefits

- Easy and quick installment.
- Compact size.
- Minimal maintenance.
- Effective functionality
- Offers many years faultfree function
- Great for repowering

**VOLVO
PENTA**

PRODUCT INFORMATION

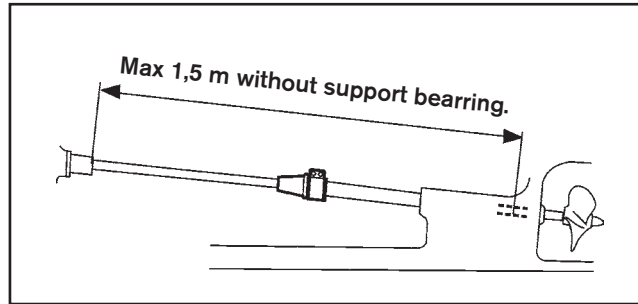

It's crucial that the shaft are within tolerance and straight or the installation may cause damage to the seal and leakage into the boat.

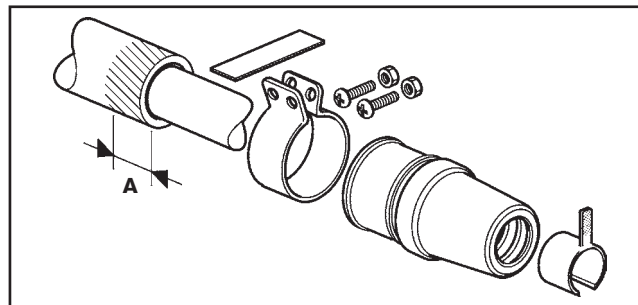
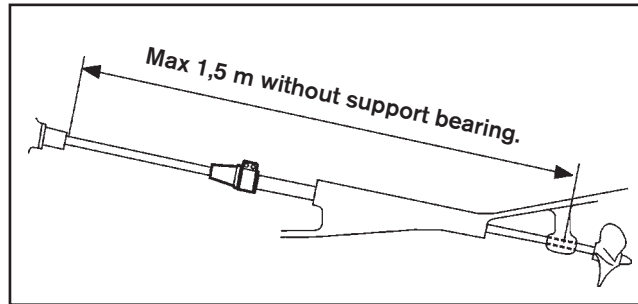

Always make sure that there is a minimum of 36 mm's (A) length at the end of the sleeve to ensure a proper assembly.

Components

Shaft diameter	Sleeve diameter	Part no.
25 mm (+0 /-0.1)	42 mm (+0.5/-0.3)	828254
30 mm (+0 /-0.1)	48 mm (+0.5/-0.3)	828422
35 mm (+0 / -0.15)	54 mm (+0.5/-0.3)	828526
40 mm (+0 / -0.15)	60 mm (+0.5/-0.3)	828527
45 mm (+0/-0.2)	64 mm (+0.5/-0.3)	3819722
50 mm (+0/-0.2)	70 mm (+0.5/-0.3)	3819723
1 " (+0/-0.1)	1 3/4" (+0.5/-0.3)	3819724
1 1/4" (+0/-0.1)	2" (+0.5/-0.3)	3819725
1 1/2 " (+0/-0.15)	2 1/4" (+0.5/-0.3)	3819726
1 3/4 " (+0/-0.2)	2 1/2" (+0.5/-0.3)	3819727
2 " (+0/-0.2)	2 3/4" (+0.5/-0.3)	3819728

Note! The rubber stuffing box is not recommendable to use with installations where flexible couplings are being used.

VOLVO PENTA

AB Volvo Penta
SE-405 08 Göteborg, Sweden